

**CONTROL
CONCEPTS
INC.**

**INSTRUCTION MANUAL
MODEL 1029C**

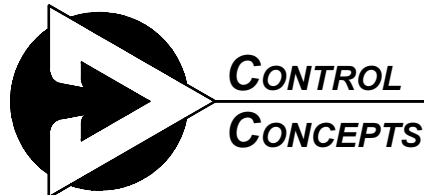

Distributed Worldwide By
www.mcgoff-bethune.com
1-800-303-4705
+1-770-840-9811

DESCRIPTION:

MODEL COVERED:

This manual describes the Control Concepts' model 1029C controller with the following ratings:

CURRENT: 50 Amps to 750 Amps.

VOLTAGE: 120 Vac to 575 Vac. @ 50/60 Hz.

GENERAL DESCRIPTION:

The model 1029C is a single-phase, phase-angle power controller.

The model 1029C has selectable feedback, dual command signals, adjustable current limiting, over-current trip, shorted SCR detection, estimated output voltage metering and output current metering.

FEATURES:

CURRENT LIMITING:

A user adjustable setting prevents the load current from exceeding a preset value.

OVER CURRENT TRIP:

If the SCR current exceeds this preset value, a relay with form C contacts is energized, an LED is lighted and the SCR's are prevented from turning on.

This provides a means to initiate an alarm or to remove system power in the event that excessive current occurs. Momentary closure of a remote switch or momentary interruption of main power will reset the O.C.T. circuit.

SOFT START AND MISSING CYCLE DETECTION:

The output voltage is ramped from zero to the desired output at a ramp rate equivalent to a time constant of 0.2 seconds on power interruptions of 1/2 cycle or more.

This feature prevents inrush currents when controlling variable resistance loads or inductive coupled loads.

SHORTED SCR DETECTION:

A relay with form C contacts and an LED is energized in the event an SCR fails in the ON state.

This provides a means to initiate an alarm or to remove system power in the event an SCR fails in the "ON" state.

STATUS INDICATORS:

Command - The intensity of the command indicator is proportional to the command signal and the "ON" time of the SCRs.

Load - The intensity of the load indicator is proportional to the load current.

Shorted SCR - When "ON", an SCR has failed in the shorted mode.

Over Current Trip - When "ON" indicates that load current has exceeded the preset Over Current Trip level.

RUN OR IDLE INPUT SELECTION:

With this feature, either of two command signals can be selected by a remote switch. This allows the controller to be conveniently switched from a "RUN" to an "IDLE" state, or from an "AUTOMATIC" to a "MANUAL" control.

CHOICE OF FEEDBACK:

The Average value of the load voltage, the RMS value of the load voltage or the RMS value of the load current can be linearly controlled with respect to the command signal.

The power (watts) applied to the load can also be linearly controlled with respect to the command signal. (Power feedback is an option that must be factory installed.)

The controller will also accept external feedback signals of 0/5 Vdc or 100 uA representing other process parameters.

OUTPUT METERING:

A filtered 0/5 Vdc signal representing the load voltage and a 0/5 Vdc signal representing the load current are provided for remote monitoring.

THEORY OF OPERATION

THE SCR

The heart of the Control Concepts, Inc. power controller is the SCR (silicon controlled rectifier, sometimes referred to as a thyristor).

The SCR has two states, ON and OFF, and allows current to flow in only one direction when turned on. SCRs can remain in the off state even though the applied potential may be up to 1400 volts.

In the on state, they can pass several thousand amperes. When a small signal is applied between the gate and cathode terminals (Figure 1), the SCR will turn on within 10-100 microseconds.

Once turned on, it will remain on until the current through it is reduced below a very low value, referred to as the holding current.

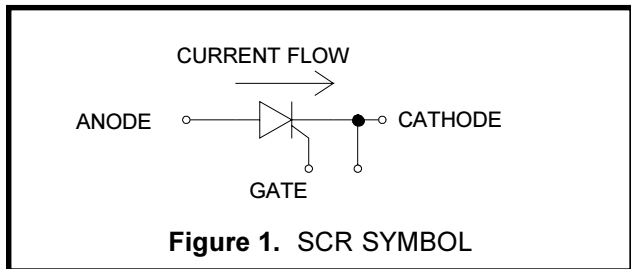

Because the SCR allows current to flow in only one direction, two SCR's are connected in an "inverse parallel" configuration to control AC current (Figure 2).

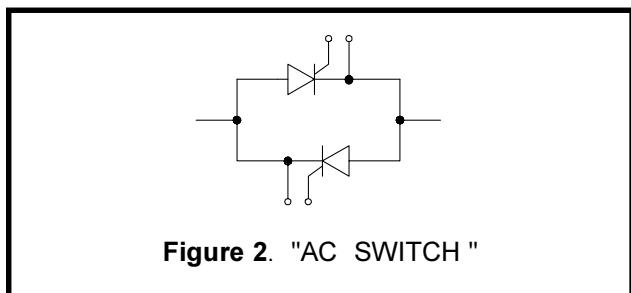

PHASE-ANGLE OPERATION

In phase-angle control, each SCR of the back-to-back pair is turned on for a variable portion of the half-cycle that it conducts. (Figure 3).

Power is regulated by advancing or delaying the point at which the SCR is turned ON within each half cycle. Light dimmers are an example of phase-angle control.

Phase-angle control provides a very fine resolution of power and is used to control fast responding loads such as tungsten-filament lamps or loads in which the resistance changes as a function of temperature.

Phase-angle control is required if the load is transformer-coupled, capacitive, inductive or a variable resistance load requiring current limiting.

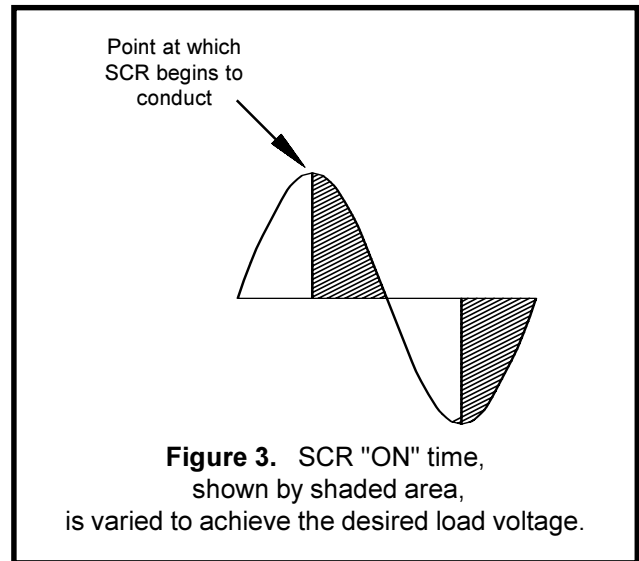

WARNING: the Control Concepts, Inc, model 1029C power controller uses power thyristors to switch voltage to the connected load. Line voltage must be assumed at the output terminals at all times, even when the control signal has been removed and the load voltage appears to be off. It has been mandated by the National Electrical Code and the Occupational Safety and Health Act of 1970 that a physical disconnect be opened ahead of all remotely actuated controls before performing any maintenance work on the controller or its connected load.

SPECIFICATIONS:																									
The following specifications apply over an ambient temperature of 0 to 55°C and a supply voltage of 85% to 110% of the nominal supply voltage rating.																									
CONTROL MODE:	Single phase SCR phase-angle control.																								
FRAME SIZE:	The “[AMPS]A” term within the model number specifies the maximum continuous RMS current rating at the maximum operating ambient temperature of 55°C.																								
RUN & IDLE COMMAND SIGNAL:	<table border="0"> <tr> <td>Command signal</td> <td>Input Impedance:</td> </tr> <tr> <td>1/5mA</td> <td>1200 ohms</td> </tr> <tr> <td>4/20mA</td> <td>300 ohms</td> </tr> <tr> <td>0-5Vdc</td> <td>200K ohms</td> </tr> <tr> <td>Potentiometer</td> <td>200K ohms</td> </tr> </table> <p>(1K, 1/4watt pot recommended for optimum linearity, up to 20K permissible) The potentiometer is excited by 5Vdc, supplied by the circuit. Other ranges may be available. Check with factory for special applications If it is desired to use a current command in both the run and idle command input, the signals must either be common sourcing, or they must be isolated from one another. Contact factory for details.</p>	Command signal	Input Impedance:	1/5mA	1200 ohms	4/20mA	300 ohms	0-5Vdc	200K ohms	Potentiometer	200K ohms														
Command signal	Input Impedance:																								
1/5mA	1200 ohms																								
4/20mA	300 ohms																								
0-5Vdc	200K ohms																								
Potentiometer	200K ohms																								
OPERATING VOLTAGE:	The standard control transformer has three user selectable voltage taps; 240, 480 & 575 Vac. Other voltages are available: 120, 240 & 480 Vac or 120, 277 & 480 Vac or 208, 380 & 480 Vac, 50/60 Hertz. Other voltages may be available - consult factory.																								
SCR RATINGS:	Peak forward and reverse voltage 1400 volts																								
SCR SURGE CURRENT RATINGS : (peak one cycle non-repetitive I_{TSM} @ 125°C)	<table border="0"> <thead> <tr> <th>Controller Rating</th> <th>Surge Current Rating</th> </tr> </thead> <tbody> <tr> <td>50 & 80 Amp:</td> <td>1750 Amps Peak</td> </tr> <tr> <td>120 Amp:</td> <td>1900 Amps Peak</td> </tr> <tr> <td>160 Amp:</td> <td>4000 Amps Peak</td> </tr> <tr> <td>200 Amp:</td> <td>4500 Amps Peak</td> </tr> <tr> <td>250 Amp:</td> <td>5200 Amps Peak</td> </tr> <tr> <td>300 Amp:</td> <td>7000 Amps Peak</td> </tr> <tr> <td>380 Amp:</td> <td>10,000 Amps Peak</td> </tr> <tr> <td>425 Amp:</td> <td>13,000 Amps Peak</td> </tr> <tr> <td>500 Amp:</td> <td>10,000 Amps Peak</td> </tr> <tr> <td>600 Amp:</td> <td>13,000 Amps Peak</td> </tr> <tr> <td>750 Amp:</td> <td>16,500 Amps Peak</td> </tr> </tbody> </table>	Controller Rating	Surge Current Rating	50 & 80 Amp:	1750 Amps Peak	120 Amp:	1900 Amps Peak	160 Amp:	4000 Amps Peak	200 Amp:	4500 Amps Peak	250 Amp:	5200 Amps Peak	300 Amp:	7000 Amps Peak	380 Amp:	10,000 Amps Peak	425 Amp:	13,000 Amps Peak	500 Amp:	10,000 Amps Peak	600 Amp:	13,000 Amps Peak	750 Amp:	16,500 Amps Peak
Controller Rating	Surge Current Rating																								
50 & 80 Amp:	1750 Amps Peak																								
120 Amp:	1900 Amps Peak																								
160 Amp:	4000 Amps Peak																								
200 Amp:	4500 Amps Peak																								
250 Amp:	5200 Amps Peak																								
300 Amp:	7000 Amps Peak																								
380 Amp:	10,000 Amps Peak																								
425 Amp:	13,000 Amps Peak																								
500 Amp:	10,000 Amps Peak																								
600 Amp:	13,000 Amps Peak																								
750 Amp:	16,500 Amps Peak																								
SCR PROTECTION:	dV/dT rating = 200 volts/microsecond. dV/dT circuit consists of a capacitor in series with a noninductive resistor. This circuit is in parallel with the SCRs. The SCRs are protected from voltage transients by a Metal Oxide Varistor.																								

SPECIFICATIONS: (Continued)	
RUN/IDLE CONTROL:	Output can be selected to be proportional to either the run command or the idle command by remote contacts. See figure 10 on Page 11.
ELECTRICAL CONNECTIONS:	Connectors for line and load are provided for copper wire from 6 ga to 250MCM on controllers rated 50 to 425 Amps. Connectors for line and load are provided for copper wire from 1/0 to 500MCM on controllers rated 500 to 750 Amps.
ELECTRICAL ISOLATION:	Heatsink to supply and load voltage: 2500 Volts Peak. Command signal to supply and load voltage: 1500 Volts Peak.
ZERO AND SPAN:	Potentiometers on the circuit board allow zero and span adjustments of $\pm 25\%$ of span for run and idle.
CURRENT LIMITING:	A potentiometer on the circuit board allows adjustment of the current limit setting from 20% to 105% of the controller rating. (The current limit potentiometer is factory set for 105% of the rated current unless otherwise specified.)
VOLTAGE METER OUTPUT:	A filtered metering signal equals 4.8 Vdc when the nominal line voltage is applied to the load. Metering load = 5mA max.
CURRENT METER OUTPUT:	A filtered metering signal equals 5.0 Vdc when the frame rating current is applied to the load. Metering load = 5mA max.
GATE DRIVE:	An optical coupled current source of 250mA with a minimum compliance of 10 volts provides the gate drives to the SCRs. Duration or "back porch" is approximately 1.4 milliseconds (60 electrical degrees).
VOLTAGE COMPENSATION:	When using voltage feedback, the load voltage remains constant, independent of supply voltage changes within + 10%, -15%.
POWER DISSIPATION:	1.5 Watts per amp of load current, per phase.
APPROVALS:	The Control Concepts, Inc. model 1029C, rated 120 to 575 Volts, at 50 to 750 Amps, is U.L. listed. U.L. File No. E136219. Call factory for information.

SPECIFICATIONS: (Continued)	
INTERNAL FEEDBACK:	User has choice of: True RMS Voltage, or True RMS Current. Power feedback can be factory installed if desired. Only one type of feedback may be selected.
EXTERNAL FEEDBACK:	An external 0 to 5Vdc or 0 to 50uA signal, (derived from the load,) may be used for external feedback into the controller. See fig. 6 on Page 5 for connections.
LINEARITY:	The controlled variable is linear within 2% of Span with respect to the command signal.
COMMAND INDICATOR:	The intensity of this green LED is proportional to the command signal.
LOAD CURRENT INDICATOR:	The intensity of this green LED is proportional to the load current.
OVER CURRENT TRIP INDICATOR:	This amber LED, when lighted, indicates the over current limit has been exceeded and the Over Current Trip relay has been energized. The SCR's will be prevented from turning on while this circuit is active.
SHORTED SCR INDICATOR:	This red LED, when lighted, indicates a shorted SCR.
O.C.T. & SHORTED SCR RELAY CONTACT RATINGS:	The Over Current Trip, and the Shorted SCR circuits, each control a relay which has form C contacts rated for 5 Amps @ 120Vac. The contacts are available on the command connector.
CONTROL RANGE:	0 to 98% of supply voltage.
ENVIRONMENT:	Operating temperature 0°C to 55°C (32°F to 132°F) Storage temperature: -40°C to 80°C (-40°F to 176°F) Humidity: 0 to 95%, non-condensing
WEIGHT:	50 & 80 Amp controllers 16 pounds 120 & 160 Amp controllers 17 Pounds 200 to 425 Amp controllers 21 Pounds 500 to 750 Amp controllers 40 Pounds
LINE 2 REQUIREMENTS:	The Line 2 connection is used for the internal control transformer which has a rating of approximately 50 VA.

INSTALLATION:

TRANSFORMER TAP:

Place the removable terminal on the transformer tap that corresponds with the supply voltage to be used.

MOUNTING AND LOCATION:

The 50 and 80 amp controller must be mounted on a vertical surface with the fins oriented so that air may flow vertically between them. The preferred orientation of forced air cooled controllers is on a vertical surface with the fan blowing the air up through the heatsink.

COMMAND INPUTS:

The 1029C has two command inputs which are selected by a contact closure. They are designated RUN and IDLE. A potentiometer, a DC voltage or a DC current may be used as a command signal into either input. These connections are made to the command connector as described below.

NOTE:

The controller is shipped from the factory with the run input (terminal 13) as the active input. If it is desired to use the idle input, (terminal 15), the electrical connection between terminals 10 & 11 must be removed. (See figures 8, 9, & 14.)

Run/Idle:

A remote switch can be used, as shown in figure 10 on Page 11, to cause the controller to be controlled by either the run or idle inputs. Connecting terminal 10 (COM) to terminal 11 (RUN/IDLE) on the command connector causes the run signal input to be in control. Opening the connection between terminal 10 and terminal 11 causes the idle signal input to be in control.

COMMAND SIGNAL OPTIONS:

Voltage:

A 0 to 5 Vdc signal may be used as the command signal by connecting the positive signal to terminal 13 (run), or terminal 15 (idle). The negative (common) signal is always connected to terminal 14 (common) (See fig. 9 or 11).

Current:

The positive current connection is to terminal 13 (run) or terminal 15 (idle). The negative or return current connection is to terminal 14 (common). See fig. 9 or 11.

When using a current command in both the run and idle command input, they must either be sourcing, or they must be isolated from one another. Contact factory for details.

Potentiometer:

A 1000 ohm to 20,000 ohm potentiometer, 1/4 watt or more, may be used to adjust the load voltage. (A 1000 ohm potentiometer provides the maximum linearity.) Connect terminal 12 to the clockwise end of the potentiometer, terminal 13 (run) or terminal 15 (idle) to the potentiometer wiper, and terminal 14 (common) to the counterclockwise end of the potentiometer. See fig. 8 or 10.

Consult factory for other options.

POWER & SAFETY CONNECTIONS:

Over Current Trip Relay:

Connections to the form C contacts of the over current relay are shown in Figure 7. The contacts are rated for 5 Amps at 120 Vac and are intended for activating an alarm and/or removing power from the system by operating a contactor or a circuit breaker.

Over Current Trip Reset:

Momentary closure of a switch connected between terminals 9 and 10 on the command connector will reset the over current relay and will release the SCRs from the locked off state. The reset switch can also be used as an on off control. Closure of the switch causes the SCRs to be immediately turned OFF. When the switch is opened, the SCRs begin operation at zero conduction angle and slew at the soft start rate to the desired output.

The Over Current Trip circuit may also be reset by a momentary interruption of supply power.

Shorted SCR Relay:

Connections to the 5 Amp 120 Vac form C contacts are shown in fig. 7. This relay energizes if an SCR fails in the shorted mode and is intended to activate an alarm and/or cause power to be removed from the system by operating a contactor or a circuit breaker.

Power Connections:

Figures 15 & 16 show typical electrical connections. The LINE 1 and LOAD 1 connectors are approved for wire sizes from 6ga to 500 MCM.

TIGHTENING TORQUE FOR LINE AND LOAD TERMINALS:

WIRE SIZE:	TORQUE
6 ga	100 IN-LBS
4 ga	100 "
2 ga	125 "
1 ga	125 "
1/0	150 "
2/0	150 "
3/0	200 "
4/0	200 "
250 MCM	250 "
500 MCM	300 "

FEEDBACK SELECTION:

Connector P2 on the circuit board allows the selection of feedback type. (See Figure 5). True RMS is the default voltage feedback mode. Average voltage feedback mode may be requested when ordering the controller.

Voltage feedback may be selected by placing the jumper across pins P2-4 and P2-7. (VFB)

Current feedback may be selected by placing the jumper across P2-3 and P2-8. (IFB)

Power feedback, if factory installed, may be selected by placing the jumper across P2-5 and P2-6. (PFB)

External feedback may be connected between terminals P1-14 (Common) and P1-18 (FD. BK.) on the command connector (See Figure 6).

A 0-5Vdc signal may be used for external feedback when the jumper is placed across pins P2-2 and P2-9 (EXT).

A 0-100uA signal may be used for external feedback when the jumper is placed across pins P2-1 and P2-10 (SJ).

Average voltage and True RMS voltage are of the feedforward technique.

START-UP:

Determine that the selected transformer tap corresponds to the line voltage.

If the customer wishes to determine that the controller and the command signals are wired and operating correctly before applying power to the load, the following procedure may be followed.

A load capable of drawing at least one amp must be connected for the controller to operate properly.

1. Move the feedback jumper to pins P2-4 & P2-7 to select Voltage FB. (See fig. 5.)
2. Determine that terminals P1-10 & P1-11 are electrically connected. Apply a command signal to the run command signal input.
3. Set the command signal to zero before applying system power. The load voltage should start at zero and increase as the command signal is increased, reaching optimum line output when command signal is maximum.
4. Remove system power from controller. Remove electrical connection from between P1-10 & P1-11. Apply a command signal to the idle command signal input and repeat step 3.

The load voltage and current may be measured with any meter. However, for accurate RMS voltage measurements use a True RMS responding meter. Use an average responding meter for average voltage measurements.

5. When start-up tests have been completed, move the feedback jumper to select the desired operating feedback.

The controller was calibrated at the factory. If adjustments appear necessary, see the zero and span adjustment instructions on page 8.

Care is urged whenever working near high voltages, and it is recommended that installation and service be done by a licensed electrician or experienced technician.

ADJUSTMENTS:

The I Span and V Span pots (and Power Span and Power Zero pots, when factory installed), are sealed at the factory. They are identified with an X in Figure 4.

Under no circumstances should adjustment of these four pots be attempted.

The setting of each of these potentiometers is critical to the proper operation of the controller.

The potentiometers labeled Run Span, Run Zero, Idle Span & Idle Zero have been calibrated at the factory and readjustment should not be necessary.

The zero pots are adjusted to provide zero output when the command signal is at minimum.

The span pots are adjusted to provide full output when the command signal is at maximum.

If it is determined that the adjustment should be changed, the following procedure should be followed.

It is assumed that the load is resistive and can draw at least one or more amps.

RUN ZERO AND RUN SPAN:

Determine that pin P1-11 (Run/Idle) is electrically connected to pin P1-10 (Common).

Make sure that the command signal is connected between the Run input P1-13 (Run/Wiper) and P1-14 (Common).

1. Set the command signal to minimum and adjust the Run zero potentiometer until the output is zero.
2. Set the command signal to maximum and adjust the Run span potentiometer until the output is at the desired maximum value.
3. The span and zero adjustments may interact, making it necessary to repeat steps 1 and 2.

IDLE ZERO AND IDLE SPAN:

Remove the electrical connection from between P1-11 (Run/Idle) and P1-10 (Common).

Make sure that the command signal is connected between the Idle input P1-15 (Idle/Wiper) and P1-14 (Common).

Repeat steps 1,2 and 3 (above) on the idle zero and span potentiometers.

It is important that meters capable of accurately measuring the output of the controller be used.

True RMS meters should be used for accurate measurements of True RMS Voltage, Current or Power (RMS Volts times RMS current into a resistive load).

Average responding meters should be used for measurements of; Average A.C. Voltage, or DC voltage.

CURRENT LIMIT:

(The current limit pot is factory set at 105% of rated current unless specified differently by the (IL) term in the model Number.)

Proper calibration of the current limit feature requires a True RMS current meter.

If it becomes desirable to reset the current limit level:

1. Rotate the current limit pot fully counter-clockwise. (This is a multiple turn pot.)
2. Carefully increase the command signal to maximum.
3. Slowly rotate the current limit pot in a clockwise direction until the desired load current is reached.

If it is suspected that the current limit adjustment is causing the output of the controller to be lower than desired, rotate the current limit pot clockwise. If the load voltage increases, the current limit adjustment has been controlling the output.

Follow the steps above to set current limit to the desired level.

OVER CURRENT TRIP:

This potentiometer has been factory set at 150% of rated frame current.

For optimum protection, the customer may wish to reduce the level at which Over Current Trip occurs.

1. Adjust command signal to maximum.
2. Slowly rotate the Over Current Trip pot counterclockwise until the Over current Trip occurs.
3. Rotate the Over Current Trip pot about 1/2 turn clockwise.
4. Reset the Over Current Trip circuit.

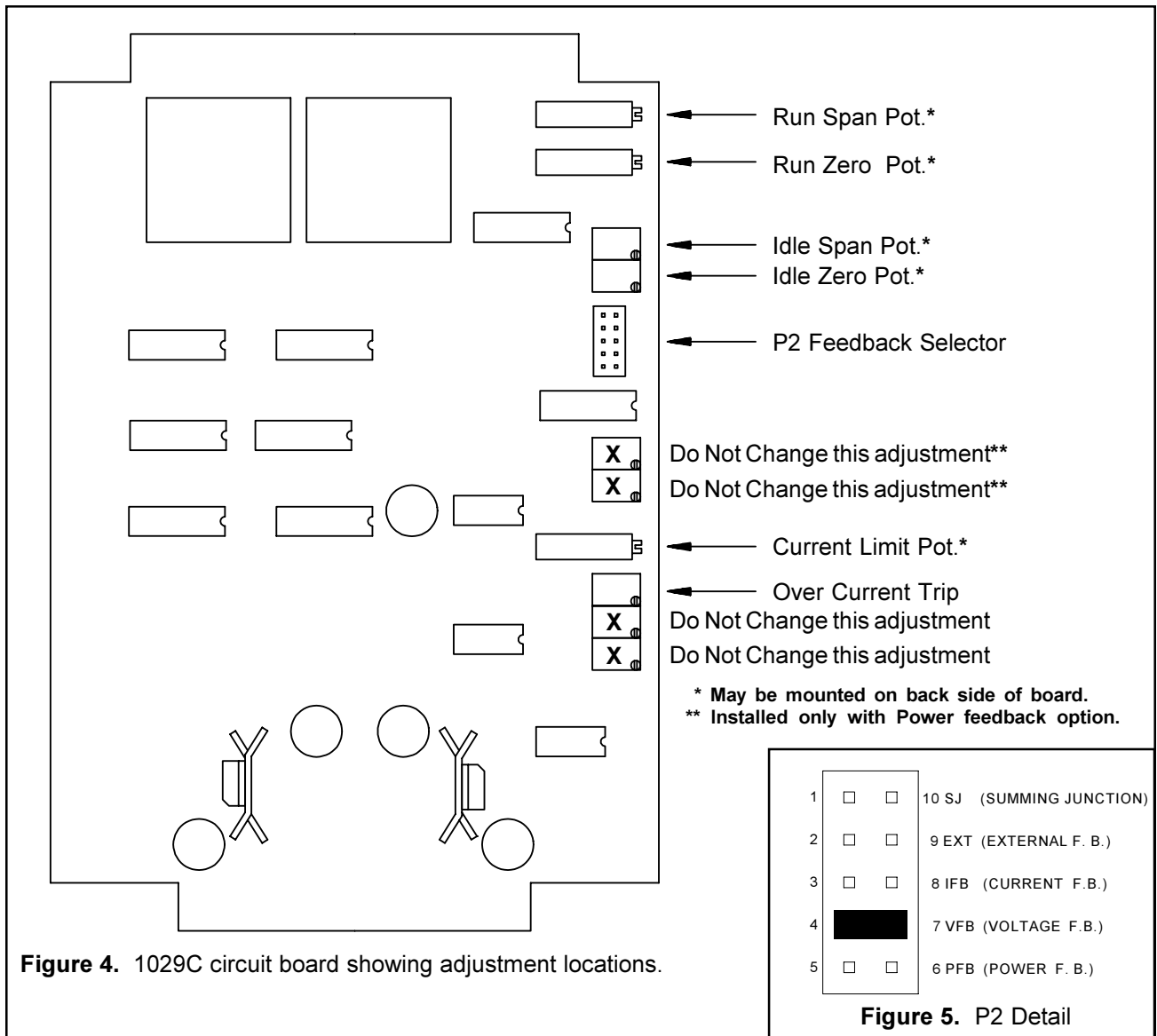

Figure 4. 1029C circuit board showing adjustment locations.

Figure 5. P2 Detail

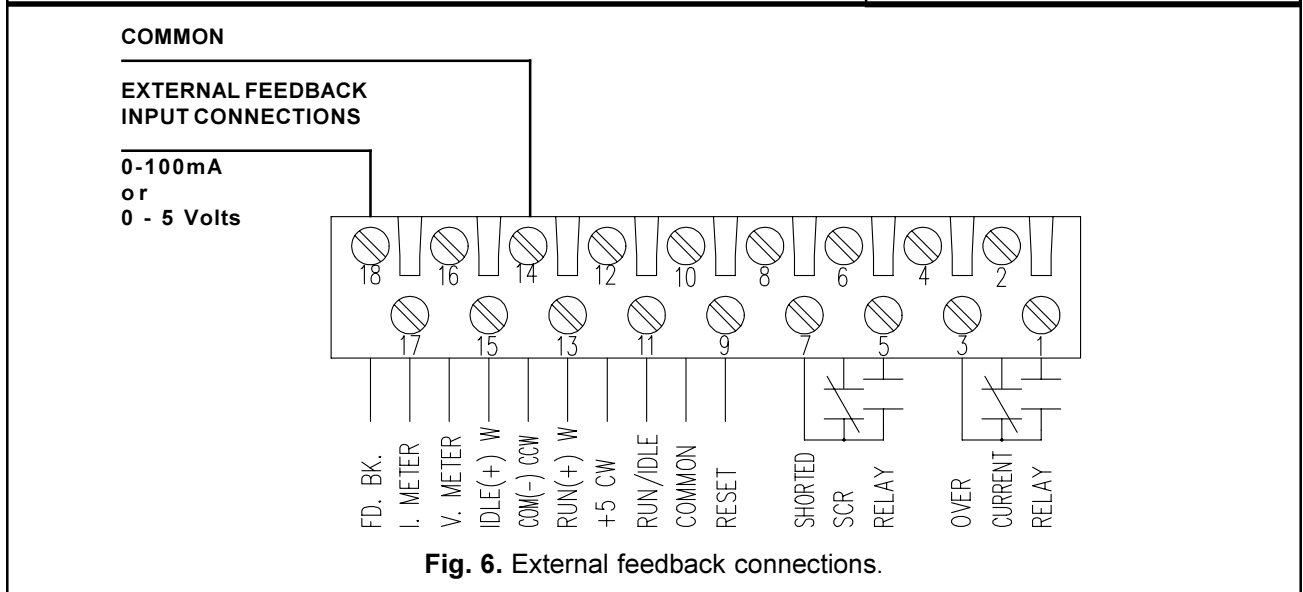
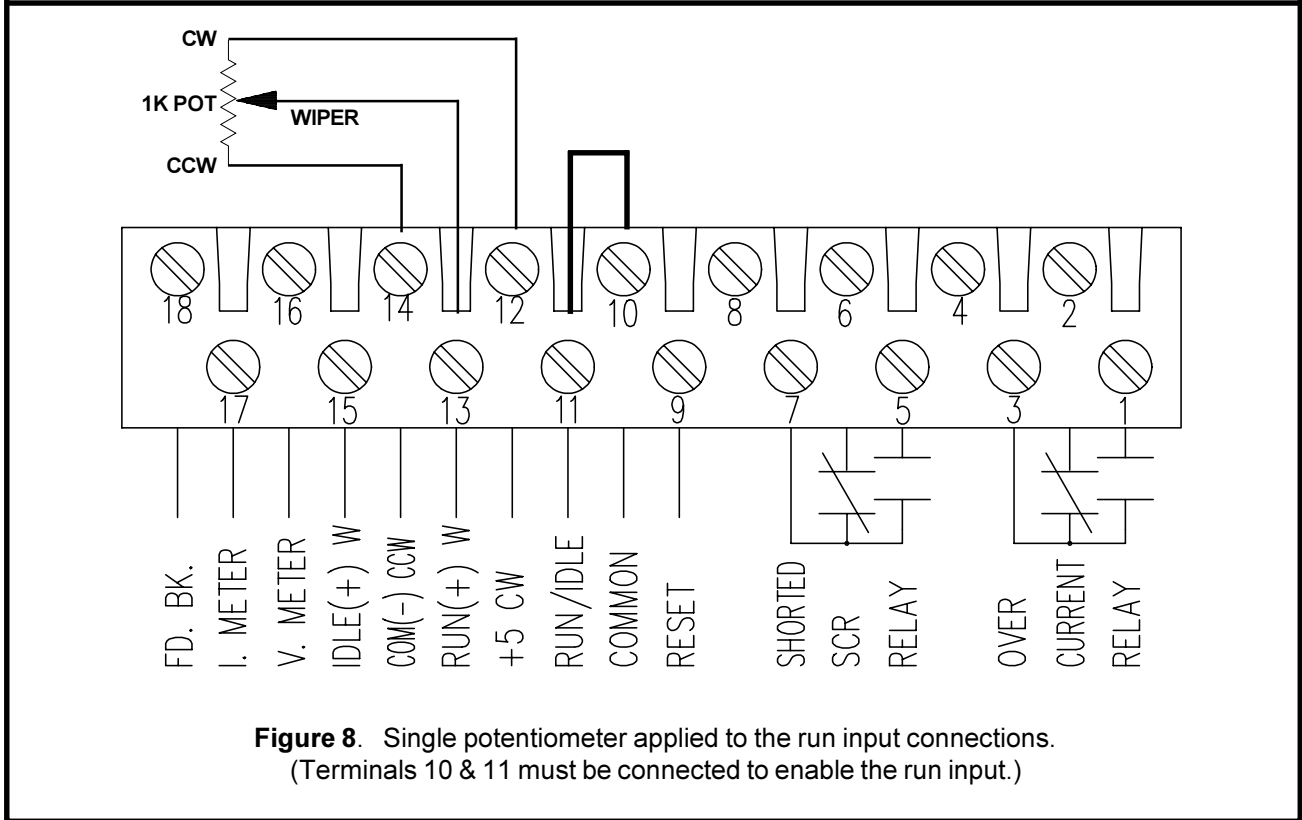
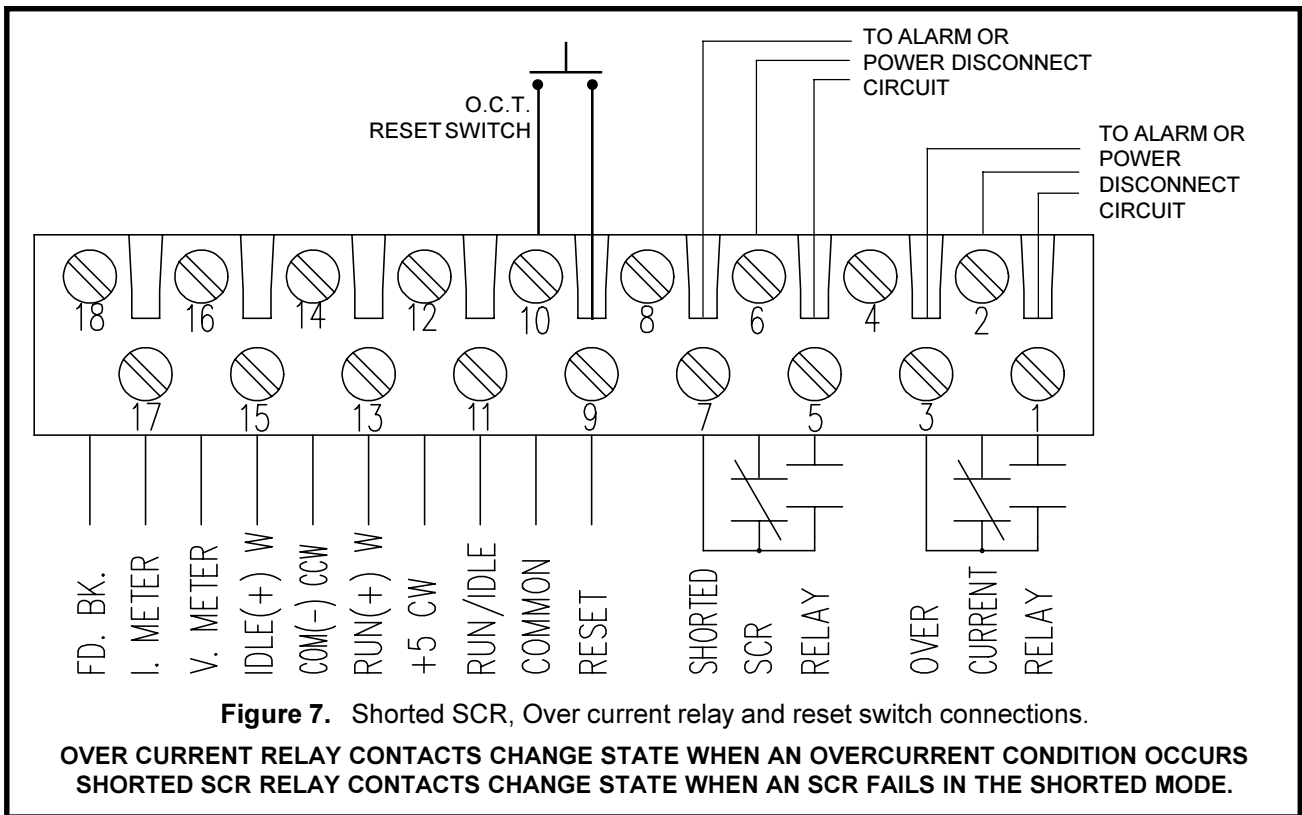

Fig. 6. External feedback connections.



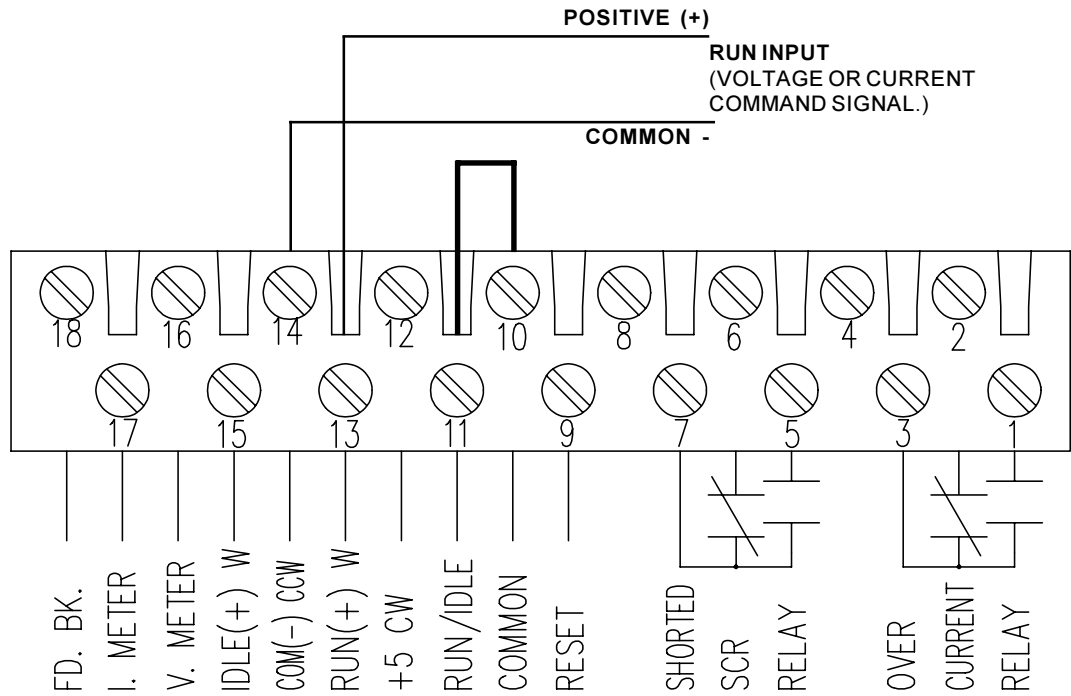

Figure 9. Single voltage or mA current applied to the run input connections.
(Terminals 10 & 11 must be connected to enable the run input.)

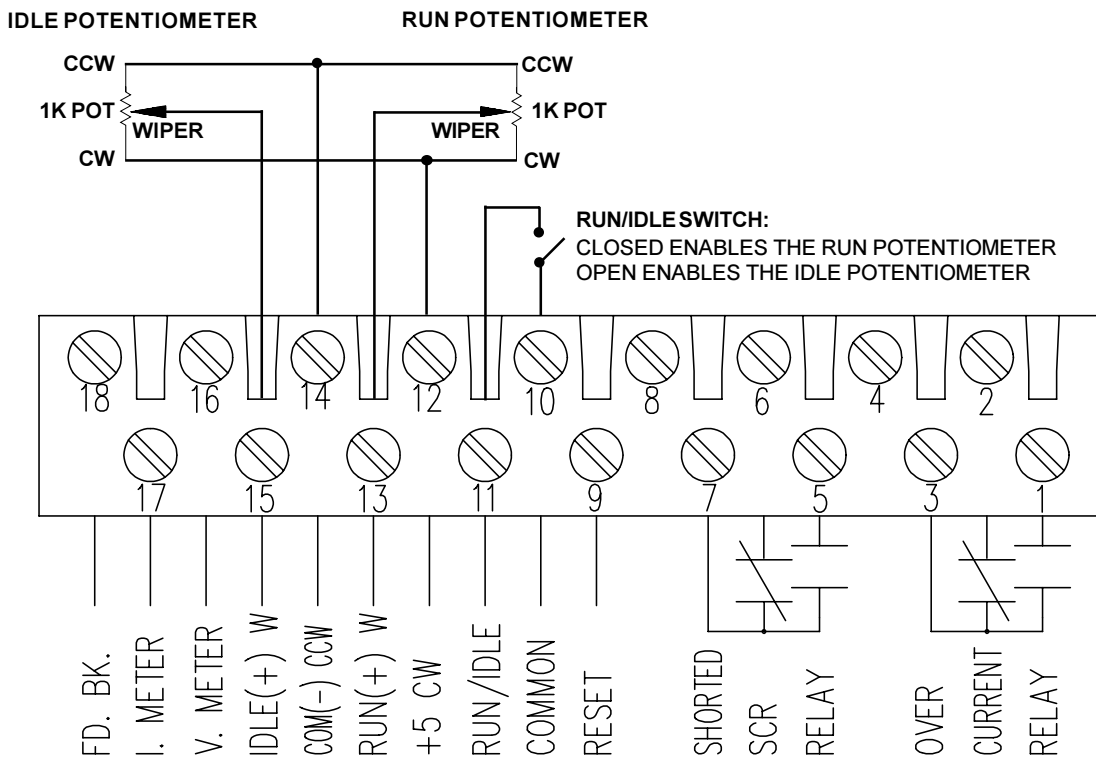

Figure 10. Run and Idle potentiometer connections

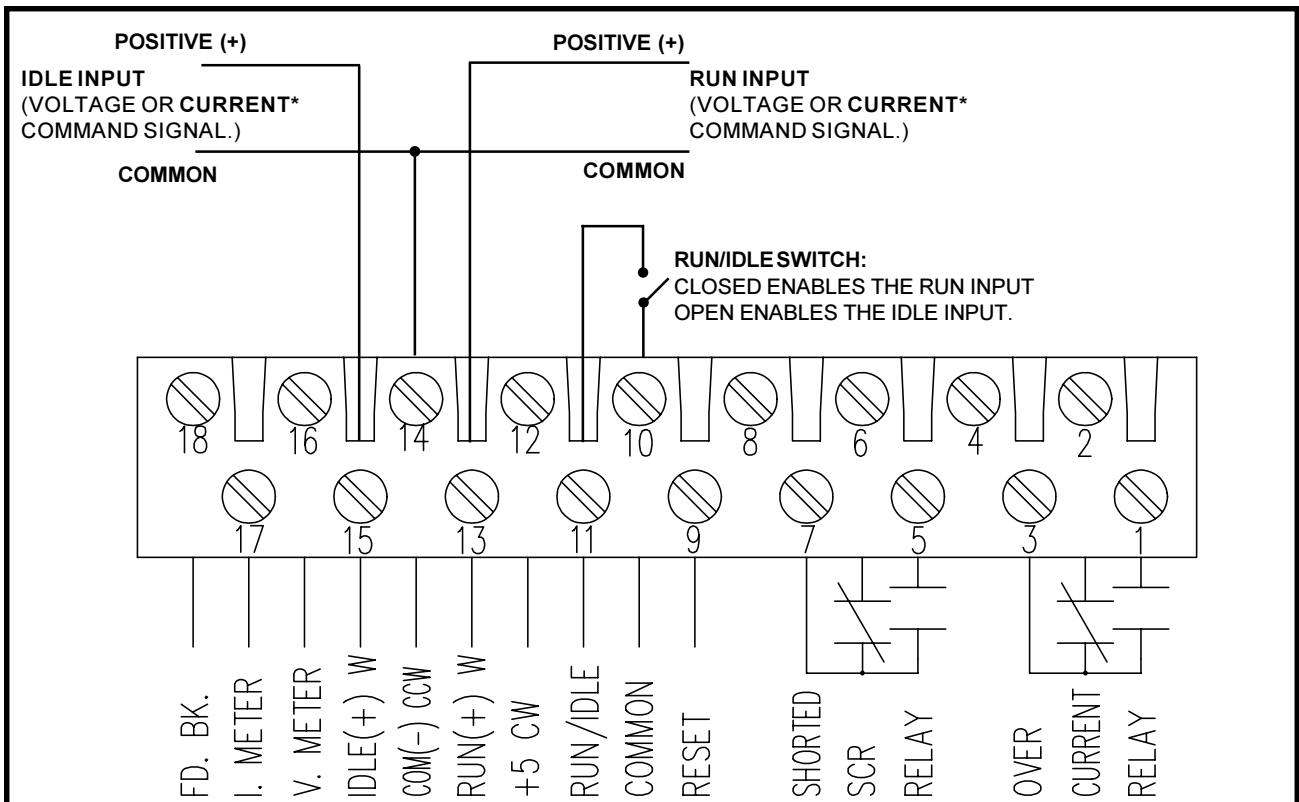

Figure 11. Run and Idle voltage and current connections.

*** If it is desired to use a current command in both the run and idle command input, the signals must either be common sourcing, or they must be isolated from one another. Contact factory for details.**

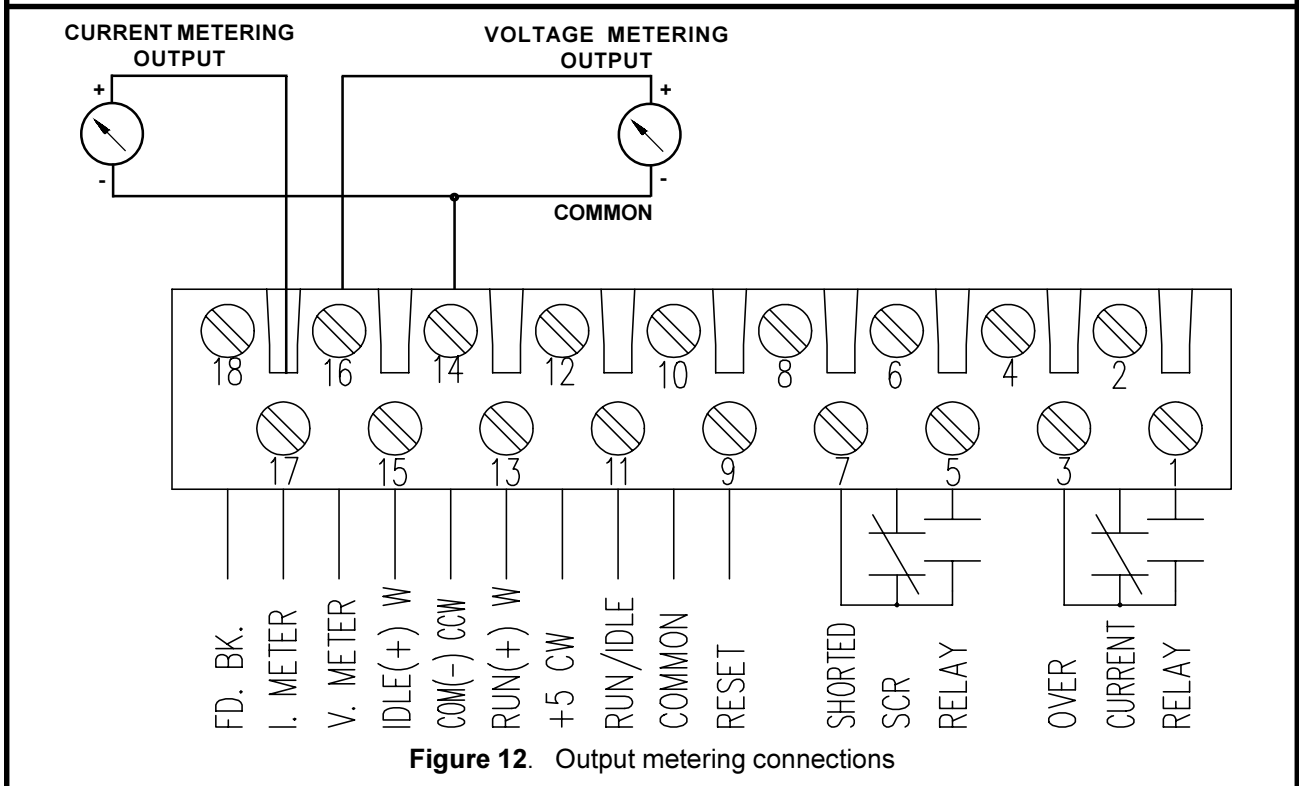
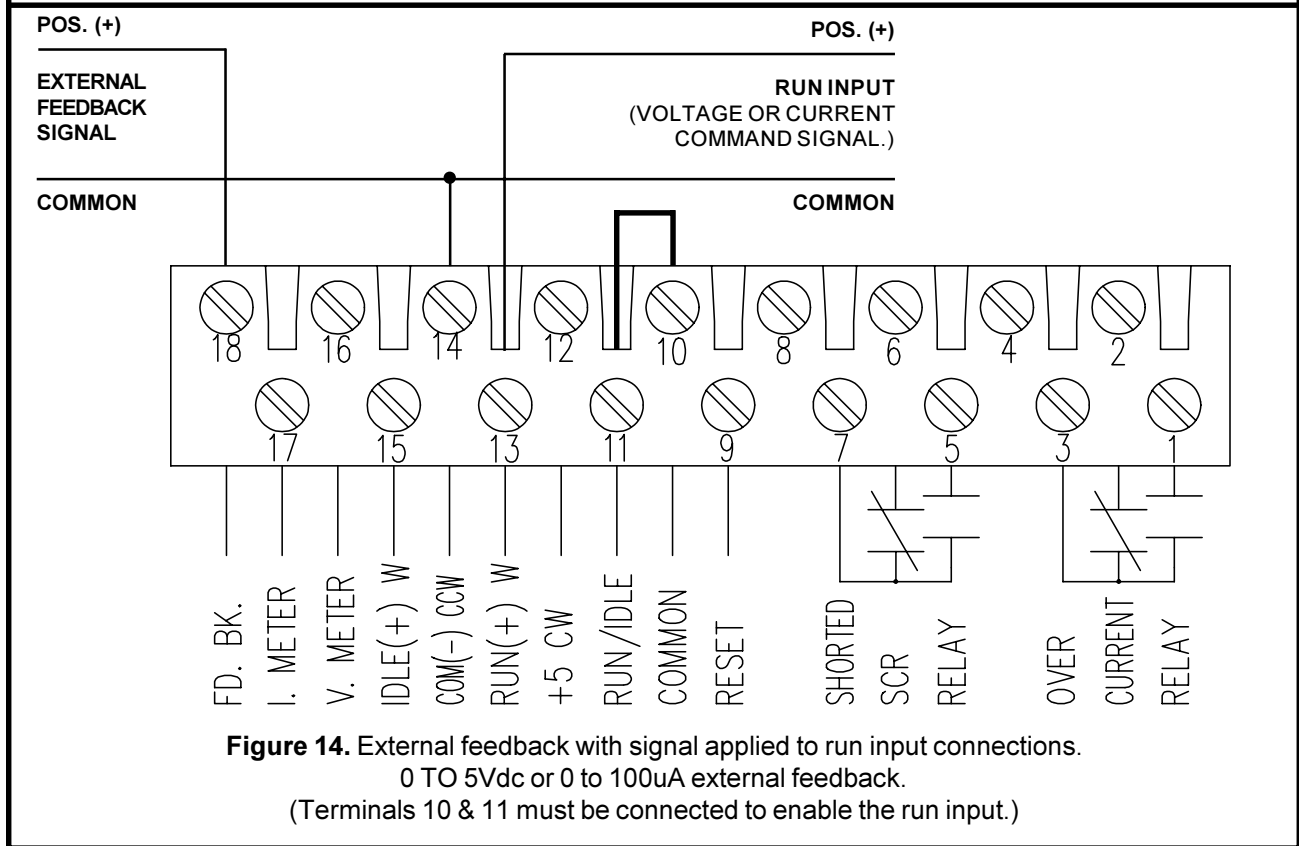
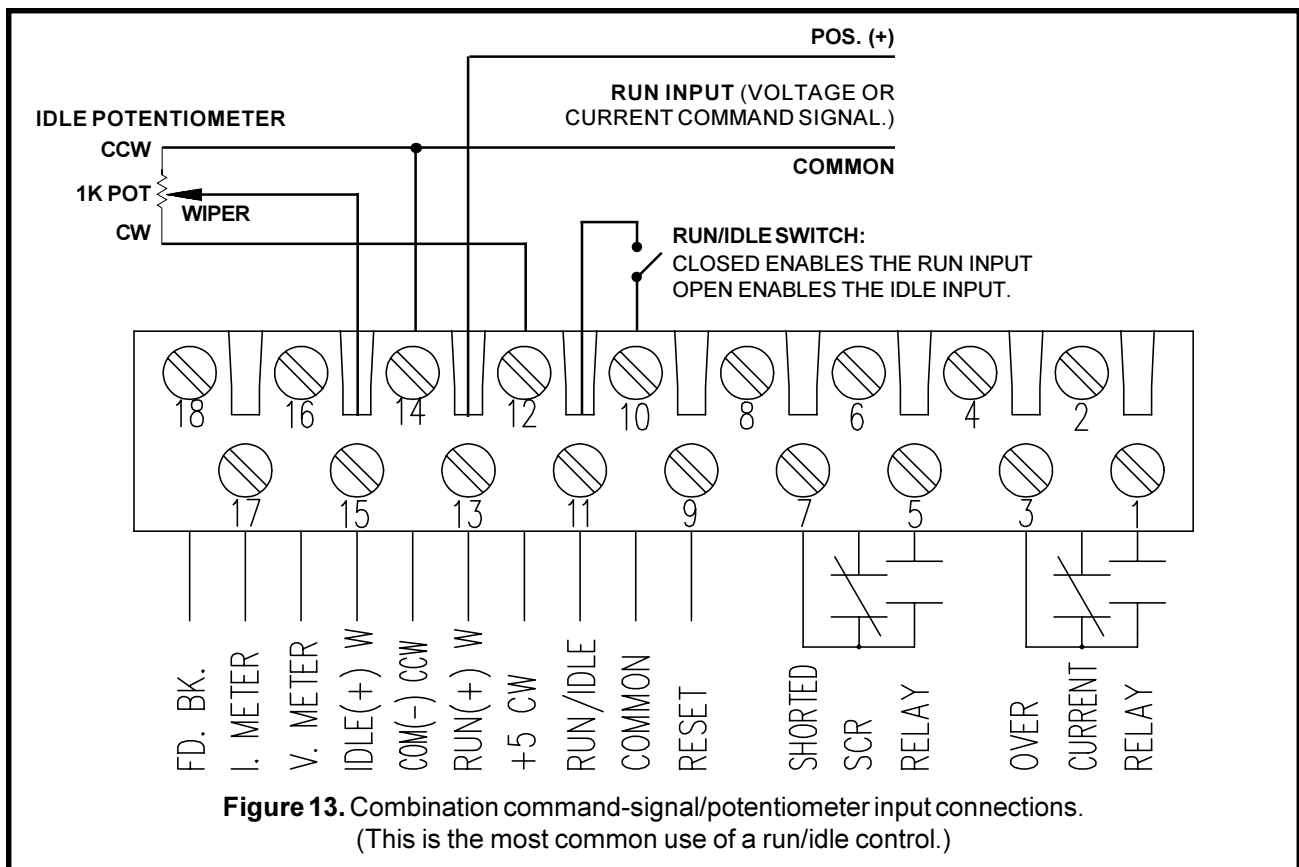

Figure 12. Output metering connections



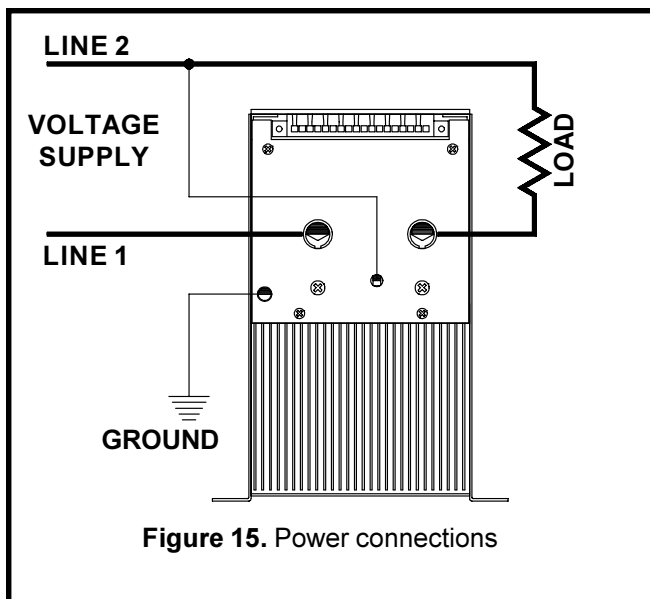

Figure 15. Power connections

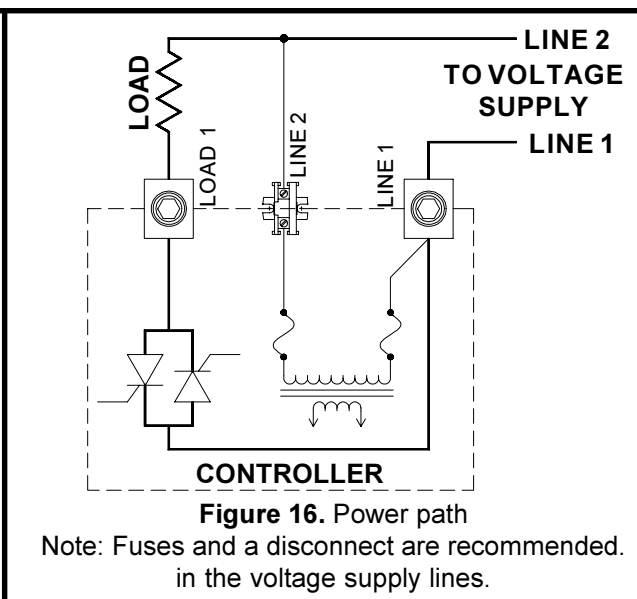

Figure 16. Power path

Note: Fuses and a disconnect are recommended in the voltage supply lines.

MODEL No IDENTIFICATION:

1029C-(FB)-(VOLTS)V-(AMPS)A-OCT(AMPS)-IL(AMPS)-R(CS)-I(CS)

The characteristics of the 1029C SCR power controller are defined by the terms in the model number as follows:

1029C The model 1029C specifies a single phase, phase-angle SCR firing circuit featuring: current limit, overcurrent trip, shorted SCR detection and electrical isolation of the command signal from the line and load voltages.

-(FB) (A, V, E, I or P[XXXAMPS])

A - Specifies *average voltage* feedback. With *average voltage* feedback, the controller varies the conduction angle (or ON time) of the SCRs such that the average voltage applied to the load is proportional to the command signal.

E - Specifies *external* feedback. The *external* feedback being proportional to some parameters such as speed, current, etc. that is ultimately being controlled by the action of the controller.

I - Specifies *RMS current* feedback. The load *current* is linearly controlled with respect to the command signal.

P(XXXAMPS) - The letter P specifies *power* feedback and therefore the load *power* is linearly controlled with respect to the command signal. XXX equals amp level for control of power.

V - Specifies *RMS voltage* feedback. With *RMS voltage* feedback, the controller varies the conduction angle (or ON time) of the SCRs such that the RMS voltage applied to the load is proportional to the command signal.

MAX LOAD POWER = (VOLTS)V x P(AMPS)

-(VOLTS)V - Specifies the supply voltage the controller has been calibrated to operate at.

Note: unless otherwise specified, the controller is equipped with a transformer that has primary voltage taps at: 240, 480 or 575 volts, 50/60 Hz. Other voltages are available: 120, 208, 277 or 380 Vac.

-(AMPS)A - Specifies the continuous RMS current rating.
50, 80, 120, 160, 200, 250, 300, 380, 425, 500, 600 or 750 Amps.

-IL(AMPS) - Specifies the current limit in Amps.

-OCT - Specifies the over current trip in

(AMPS) Amps.

-R(CS) - Specifies the run command signal.
R0/5V, R4/20mA or RPOT

-I(CS) - Specifies the idle command signal.
I0/5V, I4/20mA or IPOT.

Contact factory for special applications.

Example:

1029C-A-480V-80A-IL75-R0/5V-IPOT

Will order a 1029C controller with average voltage feedback, rated @ 480 Volts, 80 Amps, current limit set at 75 Amps, run command signal of 0 to 5Vdc and a potentiometer on the idle command input.

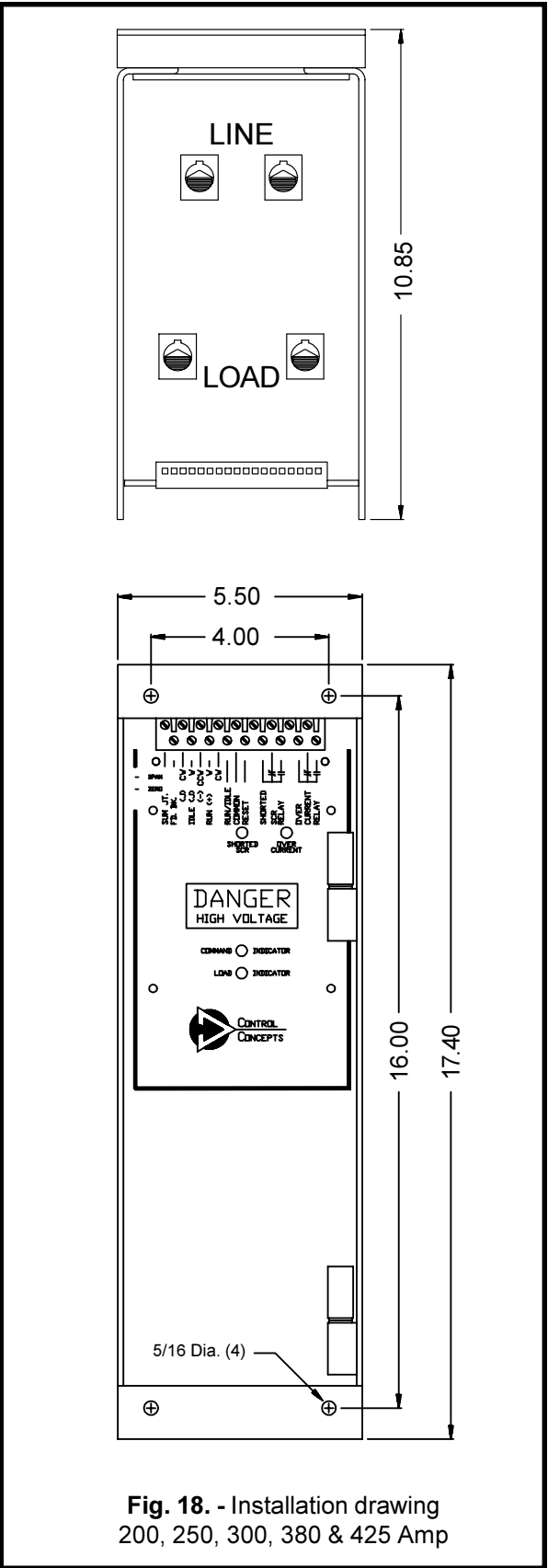
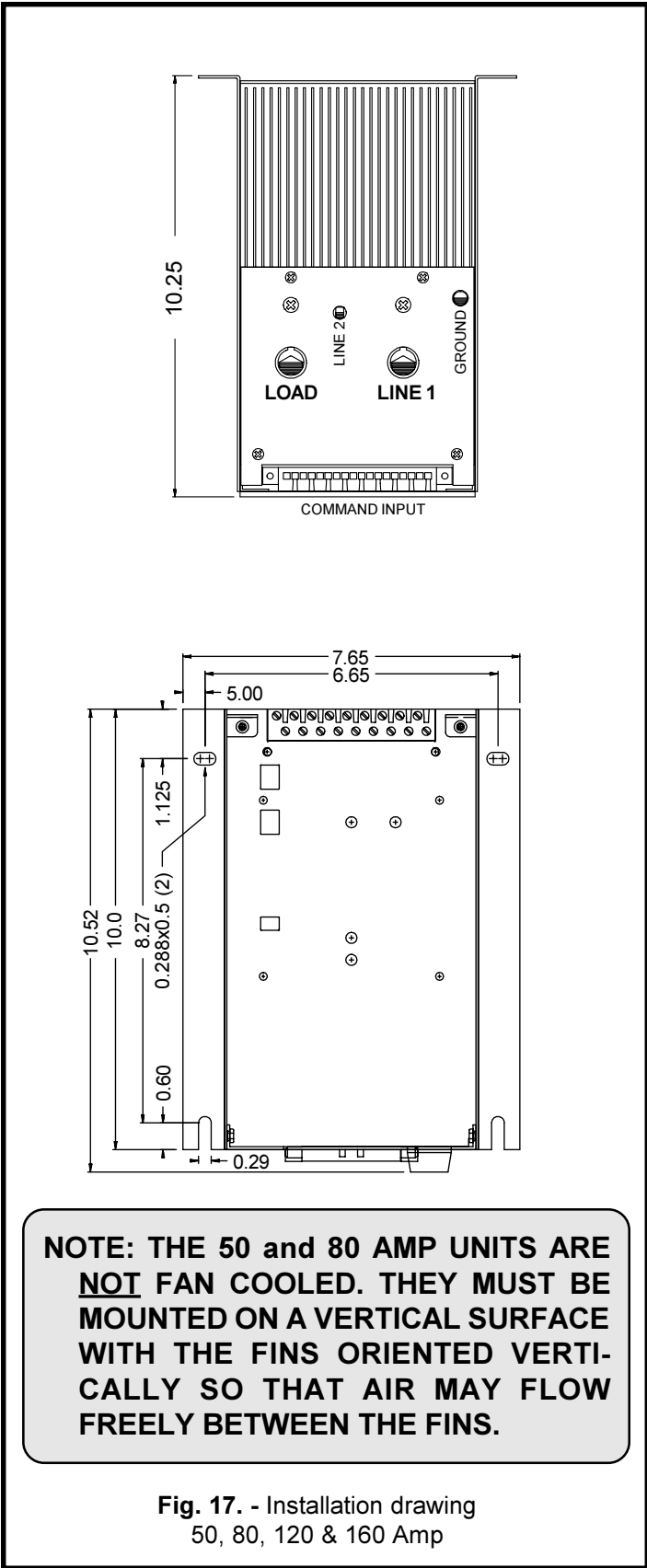

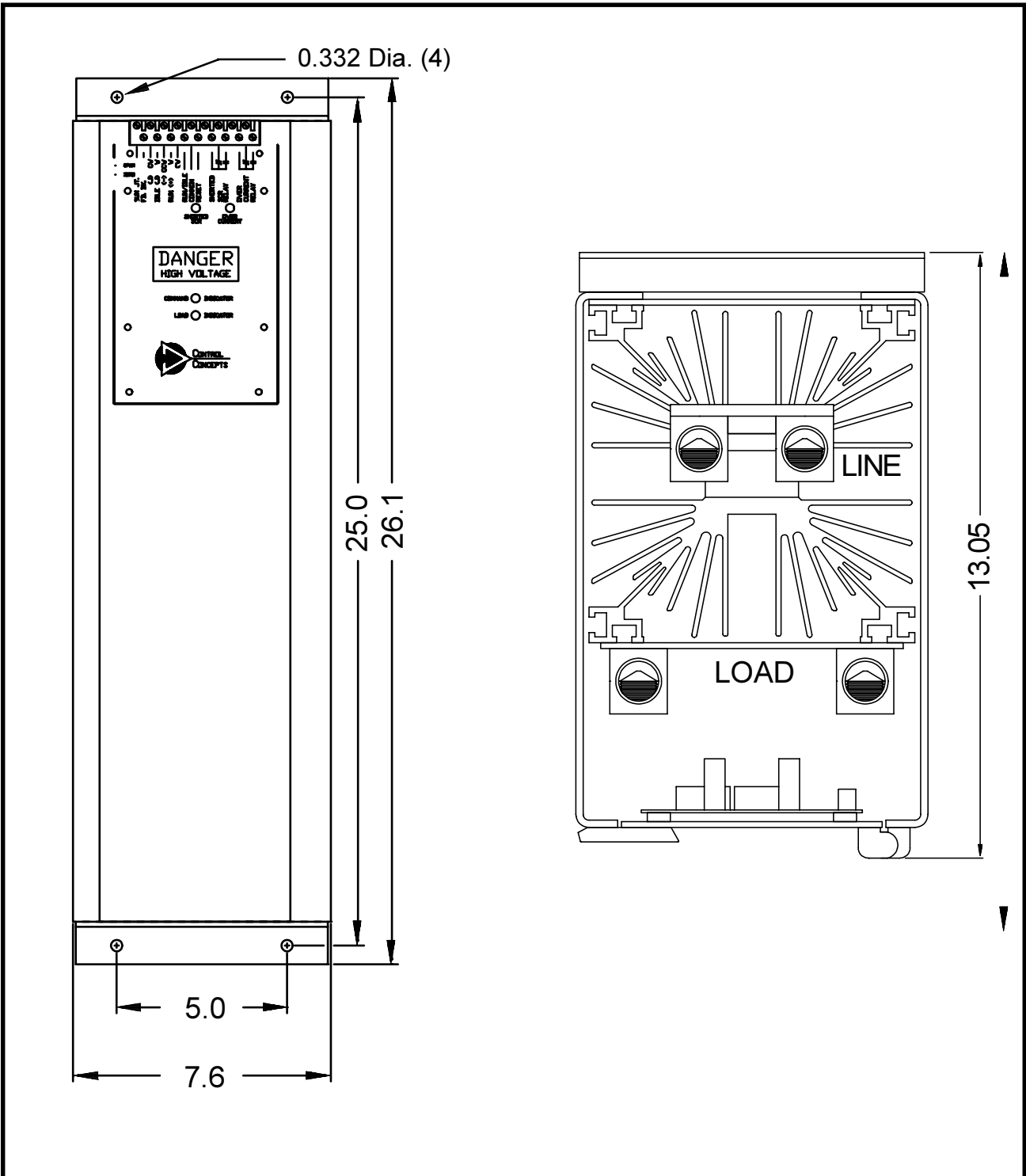

Fig. 19. - Installation drawing
 500, 600 AND 750 Amp Controllers

TROUBLE SHOOTING:

CAUTION: HIGH VOLTAGES ARE PRESENT ON THIS CONTROLLER AND ON PORTIONS OF THE PRINTED CIRCUIT BOARD. USE EXTREME CARE TO AVOID ELECTRICAL SHOCK.

Notes: The indicator LED's provide a convenient method of determining the general location of controller problems.

The LOAD LED lites when 10% or more of rated load current is present. LOAD LED intensity should increase as the command signal is increased.

The COMMAND LED indicates the operation of a large part of the circuitry. The intensity of the command indicator should be proportional to the command signal.

The OCT LED is a fault indicator to warn that an Over Current Trip has occurred.

The Shorted SCR LED is a fault indicator to warn that one or more SCR's may be shorted.

NO LOAD VOLTAGE:

Determine that the command light varies with the command signal.

If the command light does not vary.

Determine that the following conditions exist: (Measure voltages at screw terminals to ensure good electrical connections.)

- Determine if over current trip LED is ON.
- Voltage between COM (Pin 14) and +5CW (Pin 12) is 5 Volts ± 1 . If not; Circuit is not receiving power or command connections are shorting out supply. Determine that line voltage exists between Line 1 and Line 2. Determine that fuses on controller are OK. Remove connections to CW (terminal 12).
- Voltage or potentiometer inputs. Determine that voltage from COM (pin 14) to IDLE (W) or RUN (W) changes from 0 to 5 Vdc as command is changed from zero to 100%.
- 4/20 mA inputs: Determine that voltage from COM (pin 14) to IDLE (W) or RUN (W) changes from 1.2 to 6 Vdc as command is changed from 4 to 20 mA.
- Determine that there is no connection between terminals 9 & 10.

If command light can be varied:

- Determine that the load fuses are OK and that the load has continuity. Load continuity (including load fuses can be confirmed by determining that the supply voltage exists between terminals Line 1 and Load 1 when the command signal is zero.

LOAD VOLTAGE WILL NOT GO TO ZERO:

If RMS value of the load voltage is greater than 10 percent of the supply voltage.

- Determine Shorted SCR LED status while varying the command signal.
- With power removed and the load disconnected from terminal Load 1 the resistance between terminals Line 1 and Load 1 should be greater than 1000 ohms.
- If the resistance between Line 1 and Load 1 is less than 1000 ohms the SCR module has failed.
- If the shorted SCR led is ON & the resistance between Load 1 and Line 1 is greater than 1000 ohms, the failure is likely associated with the circuit board. Determine by removing the circuit board and applying power.
- Determine that the supply to line 2 and the load are connected to the same supply.

If the RMS value of the load voltage is less than 10 percent of the supply voltage.

- Determine that the command signal is correct. Adjust the zero and span potentiometers to achieve the desired output. (Note: The Zero and span potentiometers are factory set. Adjustment should be made with caution.

FULL VOLTAGE CANNOT BE OBTAINED:

- Determine that the control signal is at maximum.
- Determine that the controller is not in current limit. Decrease the current limit by rotating the current limit potentiometer counterclockwise, the controller is in current limit if the load voltage decreases.
- The DC voltage from terminals Line 1 to Load 1 should be less than 1 volt. If the voltage is greater than 1 volt, either the circuit card or the SCR module has failed.
- If the problem occurs on initial start up, determine that line 2 and the load are connected to the same supply.

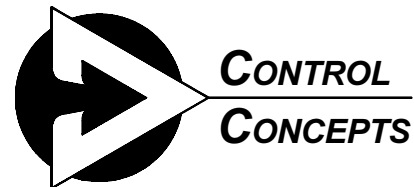

SPARE / REPLACEMENT PARTS:

TO ORDER A SPARE FIRING CIRCUIT:

1029C - (FB) - IL() - R(**CS**) - I(**CS**) - FC - FR(XX)

1029C: The model number of the controller

(FB) The type of feedback used
 A = Average voltage feedback
 V = True RMS voltage feedback
 E = External feedback
 P = Power feedback (optional)

IL () The current limit in Amps

R(cs) The run command signal

I (cs) The idle command signal
 (cs = 4/20mA, 0-5V, 0-10V or POT)

FC Firing circuit

FR(xx) The current rating of the frame
 (xx) = 50, 80, 120, 160, 200, 250, 300,
 380, 425, 500, 600 or 750 Amps

1029C - V - IL100 - R4/20mA - IPot - FC - FR120

Would be the correct number to order a firing circuit with True RMS voltage feedback, calibrated for 100A limit with a 4/20mA run signal and a potentiometer idle signal, to be used on a 120 amp frame.

TO ORDER A SPARE SCR MODULE:

CONTROLLER
CURRENT
RATING:

ORDER
CONTROL
CONCEPTS
PART No.

50 Amps	28325-0395-514
80 "	28325-0395-514
120 "	28325-0410-514
160 "	28345-0413-514
200 "	28000-0424-514
250 "	28000-0434-514
300 "	28000-0449-514
380 "	28011-0460-514
425 "	28011-0476-514
500 "	28011-0460-514
600 "	28011-0476-514
750 "	28013-0514-514

IT IS RECOMMENDED THAT THE CONTROLLER AND THE LOAD BE PROTECTED BY 600 VOLT SEMICONDUCTOR FUSES:

CONTROLLER CURRENT RATING:	RECOMMENDED BUSS CLASS T FUSE TYPE	JJS	CCI PART NUMBER:
50 Amps	60 Amps		42110-0460-360
80 "	100 "		42110-0460-410
120 "	150 "		42110-0460-415
160 "	200 "		42110-0460-420
200 "	250 "		42110-0460-425
250 "	300 "		42110-0460-430
300 "	350 "		42110-0460-435
380 "	450 "		42110-0460-445
425 "	500 "		42110-0460-450
500 "	600 "		42110-0460-460
600 "	700 "		42110-0460-470
750 "	800 "		42110-0460-480

The control transformer is protected by two fast acting class CC fuses

50 & 80 AMPS BUSS FNQ-R-1/4 42130-0460-125
 ALL OTHERS BUSS FNQ-R-1/2 42130-0460-150

REFERENCE DWG:

CCI No. D1000589B - Schematic