

## Single Phase Phase-Angle SCR Power Controller

### Features

- Phase-Angle Control
- Linear control of RMS Voltage, RMS Current or Load power with respect to a command signal independent of line voltage variations
- Adjustable Current Limit
- Adjustable Over Current Trip
- Shorted SCR Detection
- Soft Start with Missing Cycle Detection
- Run & Idle Command Inputs
- Operates at 50 or 60 Hz
- Output signals representing load current and voltage
- Plug-In & Interchangeable Circuit Card
- Diagnostic/Status LEDs
- Optical Coupled Gatedrives
- Over Temp Protection (T-Stat on Heat Sink)



### Description

The model 1029C is a single phase, phase-angle SCR power controller. The controller linearly controls, with respect to a command signal, either the RMS value of the load voltage, the average value of the load voltage, the RMS load current or load power. The controller can be configured to accept all standard industrial command signals as well as many non-standard commands.

The model 1029C is available with current ratings from 50 to 750 amperes (1000 and 2000 amp units available, consult factory) and nominal voltage ratings from 120 to 575 Vac. The controller will operate without adjustment or modification on 50 or 60 Hertz.

The model 1029C is intended for controlling transformer coupled loads, fast responding loads, and non-linear loads such as tungsten, silicon carbide, and molybdenum disilicide.

### Applications

- Variable Resistance Loads
  - Silicon Carbide
  - Molybdenum Disilicide
  - Graphite
- T-3 Lamps
- Transformer Coupled Loads
- Fast Responding Loads



## Description cont'd

### Current Limiting.

Current limiting prevents the load current from exceeding a preset user adjustable value. This feature will prevent low resistance loads from drawing excessive current. Current limiting can also be used to limit the maximum power applied to a load.

### Over Current Trip.

The over current trip provides an adjustable means to remove power when a load fault occurs. The over current trip feature, in the event of excessive current, prevents the SCRs from being turned ON and energizes a relay with form "C" contacts. The relay contacts can be used to activate an alarm or remove system power. The over current trip is preset at 150% of the current rating of the controller. The relay and operation of the controller is reset by momentary closure of a remote contact or by momentarily removing power from the controller.

### Shorted SCR Detection.

A relay with form "C" contacts is energized in the event an SCR fails in the ON state allowing full power to be continuously applied to the load. The relay contacts can be used to activate an alarm or to cause system power to be removed.

### Soft Start.

Soft start sets the output to zero on start up or after a momentary power interruption and then ramps the output to the desired level at a predetermined rate.

### Run & Idle Input Command Signal Selection.

Closure of a contact changes control from the IDLE command input to the RUN command input. This provides a convenient method of switch from auto to manual or from a RUN condition to an IDLE condition.

### Diagnostic LEDs.

The diagnostic/status indicating LEDs provide a convenient and safe method of analyzing the operation of the controller.

### Command LED.

Varies intensity with the level of the applied command signal.

### Line Current LED.

Varies intensity with the level of current in the load.

### Over Current Trip LED.

Indicates that over current trip has been activated.

### Shorted SCR LED.

Indicates that an SCR has failed in the ON state.

### Reset.

Momentary closure of a remote contact resets the controller and Over Current Trip relay. Soft Start is initiated. The Reset input may also be used as a Run/Stop control input.

### Optically Coupled SCR Gate Drives.

Optically coupled SCR gate drives provide superior transient immunity and electrical isolation than conventional techniques using pulse transformers. This technique virtually eliminates false operation and prevents SCR failure that can result when SCRs are not properly gated into the on state.

### Metering Outputs for Load Voltage and Load Current.

A 0 to 5 Vdc signal proportional to the RMS value of the load voltage and a 0 to 5 Vdc signal proportional to the RMS value of the load current are provided for monitoring the controller output.

## Wiring

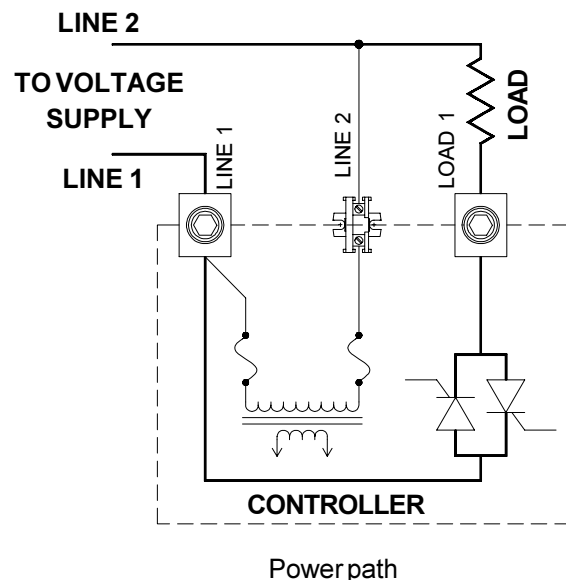
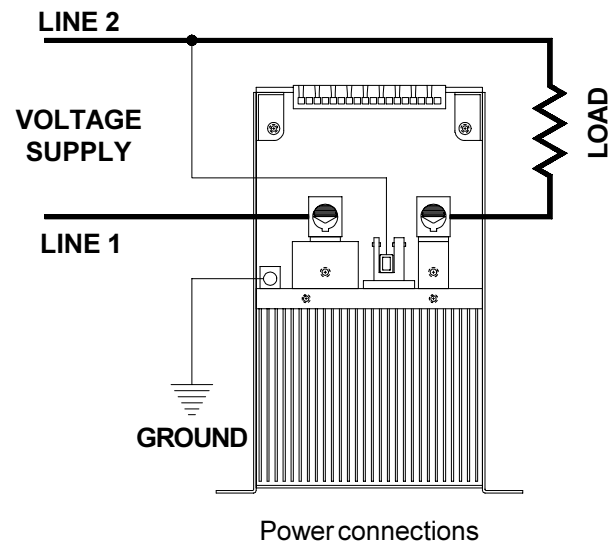

Note: Fuses and a disconnect are recommended in the voltage supply lines.

# Dimensions

(inches)

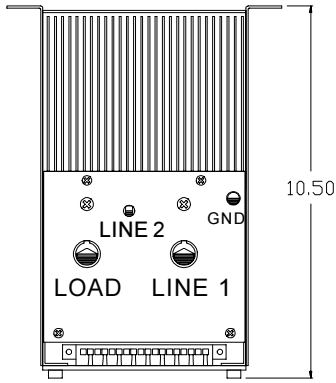

**50, 80, 120 & 160 Amps**

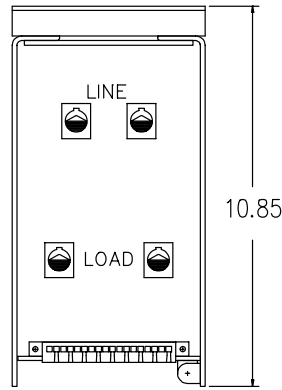

**200, 250, 300, 380 & 425 Amps**

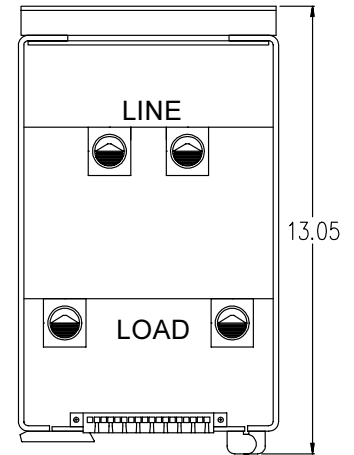

**500, 600 & 750 Amps**

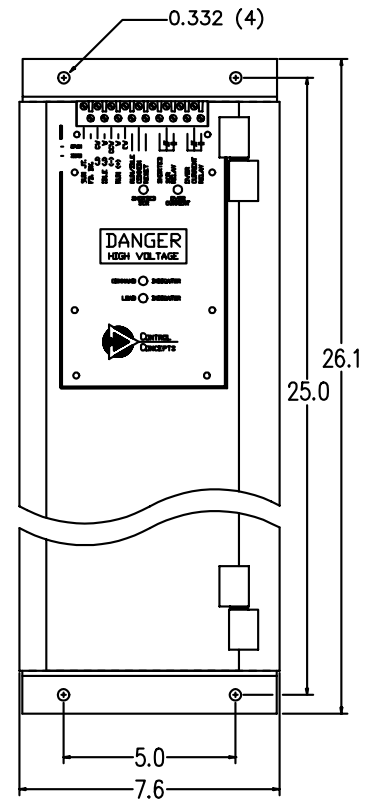
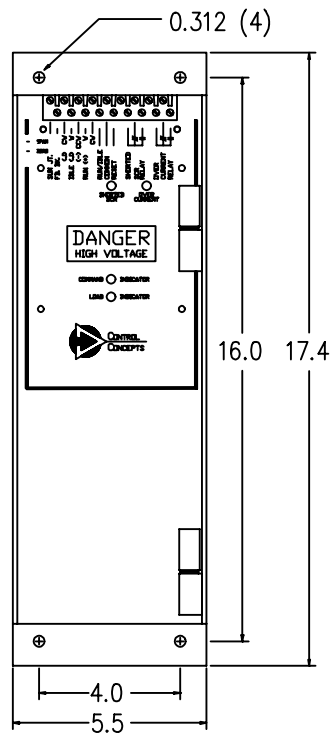
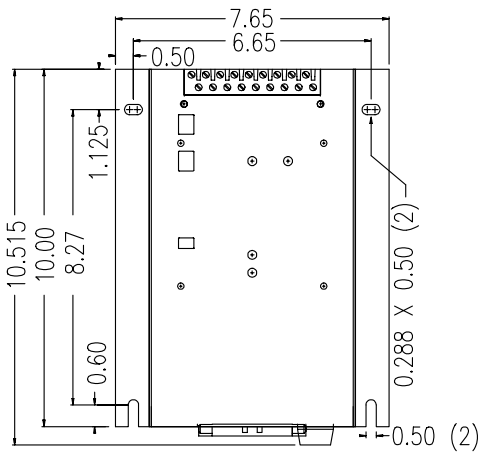

## LUG / WIRE SIZE

Amps	Lugs	Wire Size
50-160	2	6ga-250MCM
200-425	4	6ga-250MCM
500	4	6ga-250MCM
600 & 700	4	1/0ga-500MCM

## FIELD WIRING OF CARD CONNECTOR

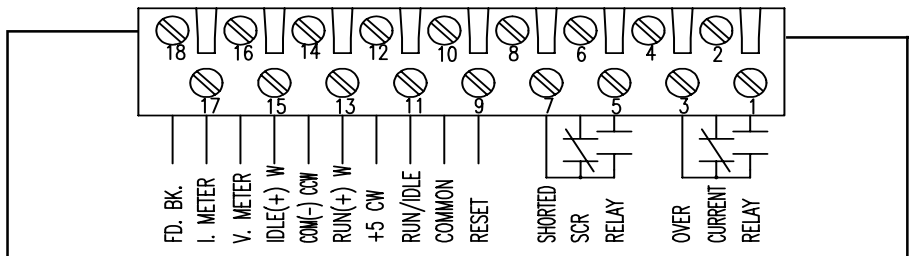

## Specifications

<b>Control Mode(s)</b>	Single-phase, phase angle control of RMS voltage, RMS current, average voltage or power applied to the load. External feedback control is also available.		<b>Line Voltage</b>	120, 240, 480, and 575 Vac, single phase, +10%, -15%, 50/60 Hz. Other voltages available.
<b>Command Signal</b>	<b>Signal</b> 0-5Vdc 1-20K Pot. 4/20mA	<b>Impedance</b> 200K Ohms 200K Ohms 300 Ohms	<b>Line/Load Connections</b>	Compression lugs provided for copper wire connections. 50 to 500 Amps      6 ga to 250MCM 600 and 750 Amps      1/0 to 500MCM
<b>Control Range</b>	0 to 98% of line voltage.		<b>Load Current</b>	Models available with current ratings of 50, 80, 120, 160, 200, 250, 300, 380, 425, 500, 600 & 750 (1000 & 2000A, consult factory).
<b>Linearity</b>	Output is linear within 2% of span over entire range of control.		<b>dv/dt and Transient Voltage</b>	200 Volts/microsecond minimum. Uses a dv/dt snubber and a metal oxide varistor (MOV).
<b>Zero and Span</b>	Factory preset.		<b>Cooling</b>	Convection cooling on 50A & 80A units. Forced air fan cooling on all others.
<b>Current Limit</b>	User adjustable over a range from 20% to 105% of rated current.		<b>Weight</b>	50A and 80A, 16 pounds; 120 and 160A, 17 pounds; 200A thru 425A, 21 pounds; 500A thru 750A, 40 pounds.
<b>Over Current Trip</b>	Adjustable. LED indication and Form "C" relay contacts for output. Preset at 150% of rated frame current.		<b>Temperature</b>	Operating: 0 to +55 C (+32 to +131 F) Storage: -40 to +80 C (-40 to +176 F)
<b>Isolation</b>	Dielectric strength, input/output and load voltage/heatsink: 2500V(RMS)		<b>Heat Dissipation</b>	1.5 Watts per amp of controlled current.
<b>Mounting</b>	Convection cooled: Heatsink fins vertical. Forced air cooled: any orientation.		<b>Fusing</b>	Special semiconductor fuses are not required. Class T fuses are recommended to protect controller and load.

## Ordering Information

1029C - V - 480V - 160A - IL135 - R4/20MA - IPOT

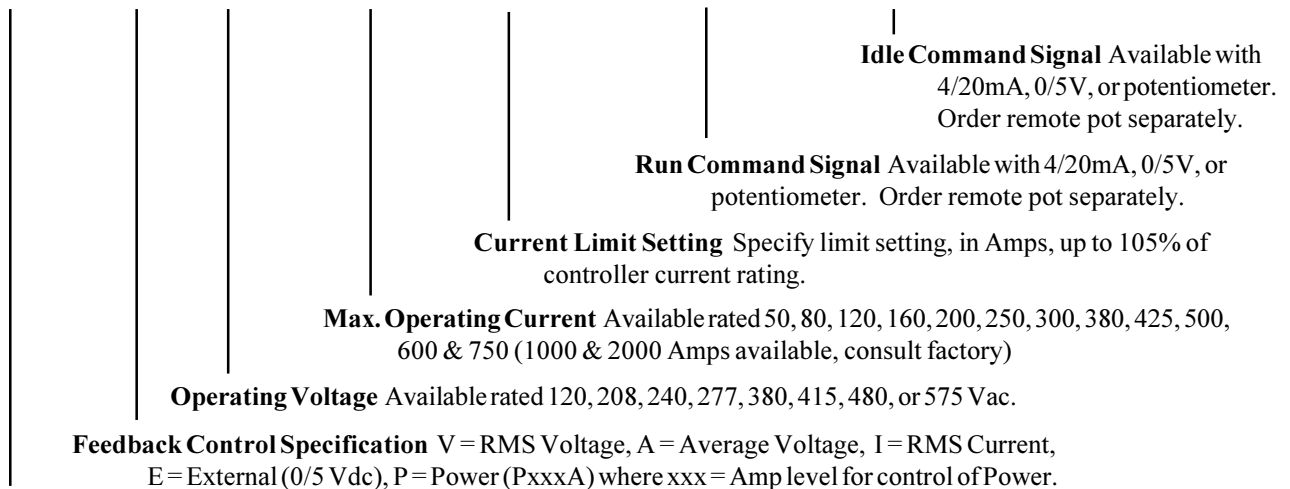

**Model 1029C** Single Phase, Phase Angle, SCR Power Controller with Adjustable Current Limit, Over Current Trip and Shorted SCR Detection.

## Complementary Products

Control Concepts, Inc., with a full range of standard and custom SCR power controllers and signal conditioners, has the expertise to meet your specific industrial power control needs. All of Control Concepts products are covered by a full two year warranty.

Call us for answers, and delivery schedules that work.

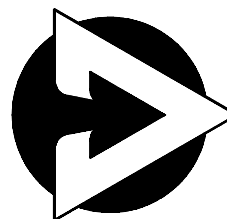

**CONTROL  
CONCEPTS**

Distributed Worldwide By  
McGoff-Bethune, Inc.

770-840-9811  
1-800-303-4705

[www.mcgoff-bethune.com](http://www.mcgoff-bethune.com)