

EA Series Actuators

Mounting Dimensions

Medium Torque and Low Torque

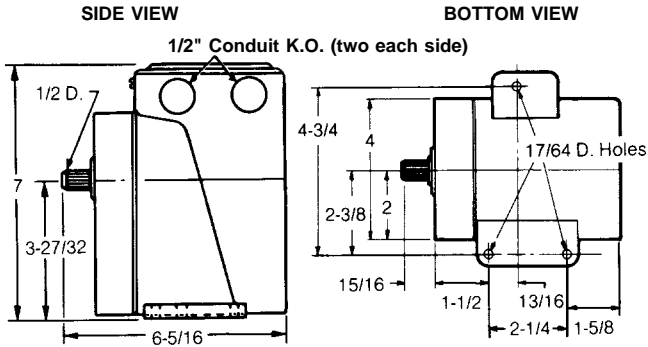

Spring Return

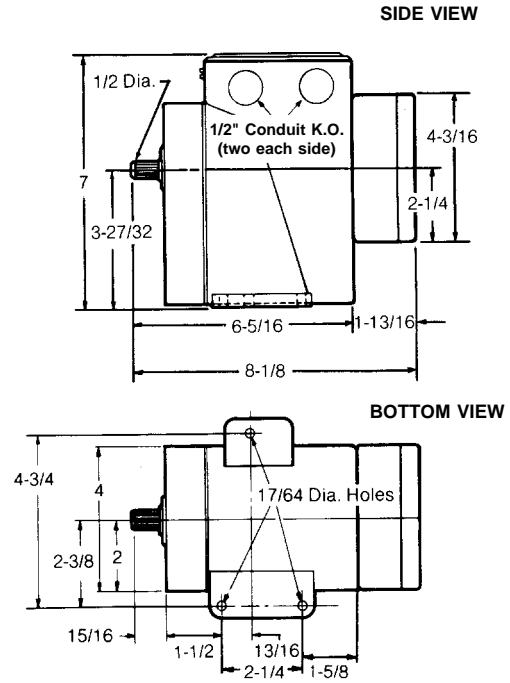

Low and medium torque and spring return output shafts have a standard 12 tooth spline. Reference ANSI B5.15.

Mounting should be upright for the longest life. Models with adjustable speed must not be mounted upside down or with the output shaft upward.

High Torque

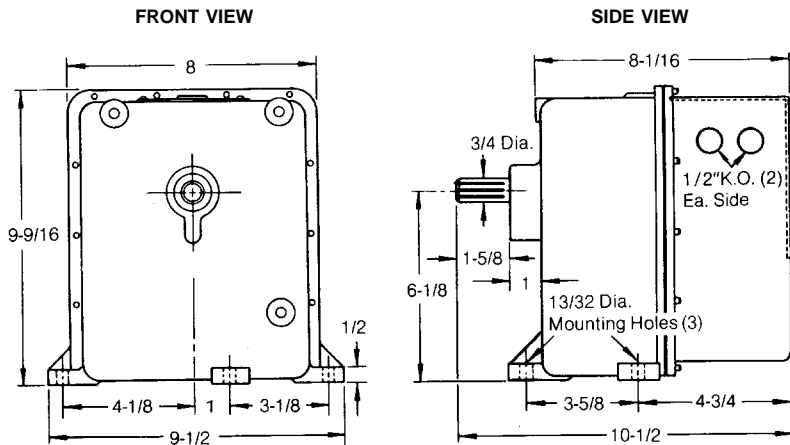

For Millimeters multiply inches by 25.4 (Inches x 25.4 = Millimeters).